

LEGEND® II

Pressure Side Pool Cleaner



Installation Guide

IMPORTANT SAFETY INSTRUCTIONS
READ AND FOLLOW ALL INSTRUCTIONS
SAVE THESE INSTRUCTIONS

Customer Service

If you have questions about ordering Pentair Water Pool and Spa ("Pentair") replacement parts, and pool products, please use the following contact information:

Customer Service/Technical Support (8 A.M. to 4:30 P.M. — Eastern and Pacific Times)

Phone: (800) 831-7133

Fax: (800) 284-4151

Sanford, North Carolina (8 A.M. to 4:30 P.M. — Eastern Time)

Phone: (919) 566-8000

Fax: (919) 566-8920

Moorpark, California (8 A.M. to 4:30 P.M. — Pacific Time)

Phone: (805) 553-5000

Fax: (805) 553-5515

Web site

visit www.pentairpool.com and www.staritepool.com to find information about our products

© 2011 Pentair Water Pool and Spa, Inc. All rights reserved.

This document is subject to change without notice.

1620 Hawkins Ave., Sanford, NC 27330 • (800) 831-7133 • (919) 566-8000

10951 West Los Angeles Ave., Moorpark, CA 93021 • (800) 831-7133 • (805) 553-5000

Trademarks and Disclaimers: Legend® and Pentair Water Pool and Spa® are trademarks and/or registered trademarks of Pentair Water Pool and Spa, Inc. and/or its affiliated companies in the United States and/or other countries. Unless noted, names and brands of others that may be used in this document are not used to indicate an affiliation or endorsement between the proprietors of these names and brands and Pentair Water Pool and Spa, Inc. Those names and brands may be the trademarks or registered trademarks of those parties or others.

IMPORTANT WARNING AND SAFETY INSTRUCTIONS



Important Notice:

Attention Installer: This guide contains important information about the installation, operation and safe use of this product. This information should be given to the owner and/or operator of this equipment after installation of the pool cleaner.

Attention User: This manual contains important information that will help you in operating and maintaining this pool cleaner. Please retain it for future reference. Consult Pentair with any questions regarding this equipment.

WARNING — Before installing this product, read and follow all warning notices and instructions which are included. Failure to follow safety warnings and instructions can result in severe injury, death, or property damage. Call (800) 831-7133 for additional free copies of these instructions.

Consumer Information and Safety

The Legend II pool cleaners are designed and manufactured to provide many years of safe and reliable service when installed, operated and maintained according to the information in this manual. Throughout the manual, safety warnings and cautions are identified by the “” symbol. Be sure to read and comply with all of the warnings and cautions.

WARNING — **Hazardous suction.** Do not play with cleaner or hose or apply to body. Can trap and tear hair or body parts. Hose can trip or entangle swimmers which could result in drowning.



WARNING — **Suction entrapment, injury, and drowning hazard.** If your pool has a dedicated suction port (“vac port”) for vacuuming or for an automatic pool cleaner, it **must be covered when not in use**. A spring loaded safety cover (a “vac port fitting”) is included with your cleaner. Install it on the suction port to prevent entrapment and injury. If the cover provided does not fit, purchase one that does from your local pool store and install it instead. The cover should conform to IAPMO SPS4-99A.



WARNING — **Stop pump** before attempting to clean unit. Do not allow swimmers in pool while pool cleaner is operating.

WARNING — To reduce the risk of injury, do not let children use or play with pool cleaner.

WARNING — Do not allow swimmers in the pool while pool cleaner is operating. Hose can trip or entangle swimmers which could result in drowning.

CAUTION — Oscillator may injure hands or fingers. **Stop pump** before attempting to clean out pool cleaner head.

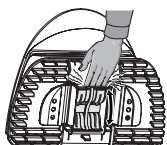

GENERAL INSTALLATION INFORMATION

Pre-installation check list

Before installing your cleaner, review and understand all warnings and safety information in this guide. Failure to follow these instructions or improper installation of the cleaner can result in damage to the pool finish or the vinyl liner, Pentair Water Pool and Spa, Inc. disclaims any liability for repairs or replacement to any of these structures or components of the customer's pool.

Before installing the cleaner in a vinyl liner pool:

Check liner closely for signs of deterioration or damage from age, chemicals, pool wall damage, etc. If any damage is found, have a qualified pool professional make all the necessary repairs. Also, if there are stones, roots, etc., under the liner, remove them before installing the cleaner.

Before installing the cleaner in a gunite pool or a pool that is partially or completely tiled:

Repair loose tiles and tighten any loose light rings.

Before installing the cleaner, clean your filter system:

Make sure you have cleaned the filter, including backwashing, rinsing, and emptying all baskets. A clean system is necessary for proper cleaner operation and coverage.

Before installing the cleaner, fill the hose with water:

Always make sure the cleaner head is submerged and the hose is full of water before connecting the hose to the filtration system (whether through a skimmer or dedicated wall fitting). Air in the system can damage the pump through dry running and overheating.

Before installing the cleaner, understand cleaner coverage:

The cleaner is designed to rid your pool of debris in approximately 4-6 hours. Less time could be needed, depending on the pool size. The cleaner was not designed to automatically clean steps or swimouts or to work under a solar cover. It was also not designed to do initial cleanup for a new pool or when opening your pool for the season.

AFTER installing the cleaner, make sure the cleaner is operating correctly :

The cleaner may need some minor adjustments to make sure it is operating properly so there is no damage to the pool finish. Certain vinyl liner patterns are particularly susceptible to surface wear, pattern removal, ink rubbing off of, or serious scratches to the pattern caused by objects coming into contact with the vinyl surface, including automatic pool cleaners. Pentair Water Pool and Spa, Inc. is not responsible for any pattern removal, abrasions or markings on vinyl liners.

WARRANTY INFORMATION

Limited Warranty Terms & Conditions

Before installing your cleaner, review and understand all warnings, safety and warranty information in this guide. Failure to follow these instructions or improper installation of the cleaner can result in damage to the pool finish or the vinyl liner, Pentair Water Pool and Spa, Inc. disclaims any liability for repairs or replacement to any of these structures or components of the customer's pool.

The Cleaner manufacturer, Pentair Water Pool and Spa, Inc. ("Manufacturer"), hereby provides the following limited warranty to the purchaser ("Customer"): WHICH IS SUBJECT ONLY TO THE FOLLOWING CONDITIONS AND EXCLUSIONS:

This limited warranty does not include replacement of parts which become discolored due to exposure to sunlight or chemicals, or parts which, even if worn, do not affect performance of the cleaner. Nicks, scratches, fading, discoloration, etc. are cosmetic conditions that do not affect mechanical performance. **Both Manufacturer and Pentair Water Pool and Spa's dealer reserve the right to deny any and all warranty claims made for worn parts if the wear does not negatively affect mechanical performance of the cleaner.**

The Cleaner is designed to function in a properly designed, constructed and maintained pool. This limited warranty does not extend in the circumstances where the pool's design, construction or maintenance is defective, substandard or inappropriate for the Cleaner's operation.

Deterioration, discoloration or brittleness of any pool finish can be caused over time separately by, or in combination with, age, an imbalance in water chemistry, improper installation, and other factors. Customer hereby disclaims any and all claims, and releases Manufacturer from any and all claims for damages to any pool plaster or vinyl liner in Customer's pool by reason of the use and/or operation of the Cleaner.

Under no circumstances shall Manufacturer be liable for any loss or damage, whether direct, consequential or incidental, arising out of the use or inability to use the Cleaner or the Hose in Customer's pool.

This limited warranty does not apply to any injury, loss, damage, defect, or malfunction of the Cleaner or failure to function resulting from any failure to operate or maintain the Cleaner in accordance with the directions contained in the Installation and Operation Manual or operating instructions provided by Pentair Water Pool and Spa or any injury, loss, damage, defect, or malfunction, or failure to function resulting from any accident, acts of God, alterations in the Cleaner by anyone other than Manufacturer; or misuse, unreasonable use, tampering, abuse, acts, omissions, failure or negligence by anyone other than Manufacturer including but not limited to such damages or injuries to parts resulting from improper installation, or damage to pump parts resulting from running the pump dry (e.g., interruption in or inadequate supply of water to internal pump parts due to loss of prime, or obstruction in lines or otherwise); or damage, defect or malfunction resulting from defects in, failure or malfunction of, or negligence, abuse, or misuse with respect to equipment other than the Cleaner; or any damage or loss of any nature whatsoever and personal injury caused due to the presence of a foreign object in or about the pool.

Disclaimer of Liability About Your Pool and Legend II

There are a multitude of factors that contribute to the life of your pool. The Legend II automatic pool cleaner is a very passive product that will have no impact on pool life.

Please be aware that over time, deterioration, discoloration and brittleness of any pool finish can be caused separately by, or in combination with, age, an imbalance in pool water chemistry, improper installation and other factors. An automatic pool cleaner, such as Legend II, will not remove or cause wear on "good" pool plaster. In fact, the opposite is true—pool plaster will eventually cause wear on the cleaner.

The same situation holds true for vinyl-lined in-ground swimming pools, because vinyl liners are also affected by the environment and factors such as pool water chemistry, sunlight and the pool's surroundings. Therefore over time, vinyl can become brittle and weak. In addition, vinyl-lined pools are affected by the workmanship, composition and installation of the liner and the workmanship and quality of construction of the supporting walls and pool base. These are all factors which can contribute to liner failure. The existence of any of these type of conditions in your pool is not caused by the use or operation of Legend II. The manufacturer disclaims any liability for repairs or replacement to any of these structures or components of the customer's pool.

The pool owner must assume all responsibility for the condition and maintenance of the pool's surface, water and deck.

LEGEND® II

LX 5000G

LX 5000GG

Important Information:

The Legend® II automatic pool cleaner comes ready to connect into a female threaded 1-1/2" dedicated return line. Other connections are possible, but they require additional fittings. For more information, please contact our Technical Support Department at 1-800-831-7133. Also, if you have a chlorinator, solar system or other air inducing equipment, please contact our Technical Support Department before you install the Legend® II.

The following are important facts to remember before installing and operating the Legend® II.

1. Always disconnect the Legend® II from the pool wall when cleaning or back washing the pool filter.
2. After cleaning or back washing, let the filtration system run for at least five minutes before reconnecting the Legend® II.
3. New plumbing lines should be flushed out before installing the Legend® II.
4. The Legend® II should not be used to remove plaster dust in new pools.
5. Always remove the Legend® II before swimmers enter the pool.
6. Always handle the Legend® II with care. Do not let children or pets play with the unit: it is not a toy.
7. Always pick up the Legend® II by the Handle especially when lifting the unit out of the water.
8. Unless checking the wheel RPM, do not handle the Legend® II while it is operating.
9. Always remove the Legend® II from the pool before chemical shock treatments. As a rule, any pool water that is unsafe for swimming is unsafe for the Legend® II.
10. Carefully cut the feed hose following the instructions on [Page 3](#).

By following these simple guidelines, you can help protect against injury and prolong the life of your Legend® II.

Before the Legend® II is installed, please take a moment to record the serial number. This number is located on your warranty card and on the back of the Legend® II near the rear jet. You will be asked this number when you contact our Technical Support Department.

SERIAL # _____

TABLE OF CONTENTS

I. Introduction	1
A. Thank You for Choosing the Legend® II	1
B. What to Expect from the Legend® II	1
II. Installation Instructions	2
A. Legend® II Components	2
B. Pool Connections	2
C. Installing the Twist Lock Pressure Relief Valve (Wall Fitting)	2
D. Pressure Testing Instructions	3
E. Cutting the Feed Hose	3
F. Hooking Up the Legend® II	4
G. Checking Operation	4
H. Fine Tuning the Legend® II	5
1. Thrust Jet Adjustment	5
2. Sweep Hose Adjustment	5
3. Checking Wheel RPM	5
III. Operation & Periodic Maintenance	6
A. Connecting/Disconnecting the Legend® II	6
B. Turning the Legend® II On/Off	6
C. Cleaning the Sand & Silt Bag	6
D. Periodic Maintenance	7
1. Wall Fitting Screen	7
2. Tires & Bearings	8
3. Roller Rings	8
4. Debris Bags	8
5. Sweep Hose	8
6. Debris Valve	8
E. Back Washing the Pool Filter	8
F. Storage and Winterizing	9
G. Accessories	9
1. Leaf Bag	9
IV. Troubleshooting and Performance Tips	10-11
Legend® II Parts List and Exploded View	12-15

I. Introduction

A. Thank You for Choosing the Legend® II Pool Cleaner

Congratulations on the purchase of your new automatic pool cleaner. The Legend® II is designed to give you years of dependable and efficient service. With the Legend® II, you and your family will spend more time relaxing and enjoying your pool and less time cleaning it.

The Legend® II has been designed and built with time proven features and innovations to create an automatic pool cleaner that will give you years of dependable service. The Legend® II is built with pride by people who care about the product using state of the art materials and backed by a limited warranty that protects against defects in parts and construction.

Like any mechanical device, the Legend® II requires some preventative maintenance and the replacement of certain working parts. We recommend that you have your Legend® II checked annually. For best results have your Legend® II installed by a qualified swimming pool professional.

For pool owners with plumbing and mechanical experience, installation instructions are included in this manual.

Please put safety first! Be sure to take your Legend® II out of your pool and store it carefully in a shaded area before anyone enters the pool.

B. What to Expect from the Legend® II

When operating correctly, the Legend® II will travel randomly throughout the pool, vacuuming and sweeping the bottom. The climbing ability of the Legend® II is dependent on the pools shape. It will climb better in pools without sharp angles or curves in the transition from the pool floor to the pool wall.

The Legend® II comes equipped with a Wall Fitting (Part# LXW22/360024) that features a Twist Lock Automatic Pressure Relief Valve. If the Legend® II is receiving too much water pressure to the unit, the relief valve can be manually adjusted to reduce water pressure.

Approximately every three minutes and 30 seconds the Legend® II will go into a back up mode. At this time the Back-Up Valve will pull the Legend® II away from it's current location increasing it's random pattern.

The Sweep Hose operates in a gentle sweeping motion to prevent debris from becoming trapped in hard to reach corners of the pool.

II. Installation Instructions

A. Legend® II Components

The Legend® II Box Contains:

1. Cleaner Head
2. Sand & Silt Bag
3. Sweep Hose (Attached to Cleaner Head)
4. Complete Feed Hose
 - a. 1 - 18 in. hose
 - b. 1 - 2 ft. hose
 - c. 1 - 4½ ft. hose
 - d. 3 - 6 ft. hoses
 - e. 1- Back-Up Valve
 - f. 4 - Swivels
 - g. 1 - Wall Fitting
 - h. 12 - Mender Nuts
 - i. 7 - Hose Floats
 - j. 1 - Pressure Tester

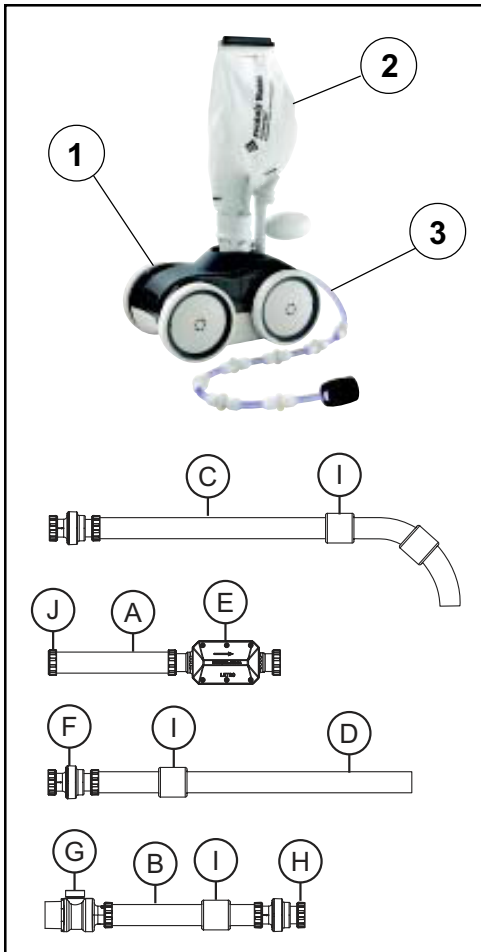

B. Pool Connections

The Legend® II comes equipped to connect to a female threaded 1-1/2" dedicated return line. An adjustable gate valve with a pressure gauge should be installed to allow a regulated amount of water flow from your pool system to the Legend® II. For more information contact our Technical Support Department at 1-800-831-7133.

Also, if the pool doesn't have a dedicated cleaner line please contact our Technical Support Department also.

C. Installing the Twist Lock Pressure Relief Valve (Wall Fitting)

1. Take out any existing pool cleaner and/or wall fitting.
2. Turn on the filtration pump and flush out the plumbing line.
3. Turn off filter pump
4. Remove the Wall Adapter from the Wall Fitting and screw Adapter by hand into the dedicated line. Turn until tight.

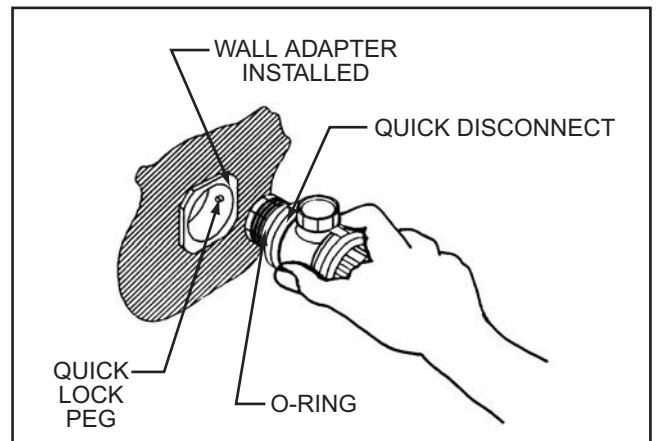

5. Take the Wall Fitting and Twist Lock the Wall Fitting into the Wall Adapter 1/4 turn; to a snug fit. Once the Wall Adapter is secure you can now twist lock and unlock to remove Wall Fitting with ease from the Wall Adapter.

D. Pressure Testing Instructions

1. Make sure the pool filter is clean before conducting this pressure test.
2. Twist lock the Wall Fitting with Feeder Hose into the Wall Adapter.
3. Have someone hold the Pressure Tester end of the Feed Hose beneath the water while you turn on the pool pump. Continue holding the hose under the water and cover the large hole of the pressure tester.
4. Reach down and feel around the Pressure Relief Valve on the Wall Fitting to see if the Relief Valve is releasing any water pressure. If valve is releasing water pressure go on to Section E. *If it is not*, the pool filtration pump may not have sufficient amount of water pressure to operate the Legend® II.

**BEFORE YOU GO TO THE NEXT STEP,
CONTACT OUR TECHNICAL SUPPORT
DEPARTMENT AT: 1-800-831-7133**

E. Cutting the Feed Hose (See Hose Diagram on Page 15)

The Hose assembly comes in 6 sections covering approximately 30 ft. of the pool, which provides ample hose for most residential pools. For larger or smaller pools, see Page 11 for instructions on *Adding or Deleting Additional Feeder Hose*.

1. Take Feeder Hose out of box and lay the hose straight in the sun for one day if possible, (this will take any memory out of the hose due to being coiled up in the box).
2. With the pool pump on, hold the free end of the Feeder Hose underwater. Gently pull the hose to the farthest end of the corner of the pool, *do not stretch the hose*. (The Legend® II usually will not climb the top step, so you do not need to include it in the measurement.) If the hose just reaches the farthest point of your pool, and without any excess hose hanging over the deck, then go to Section F.
3. If the Feeder Hose extends past the farthest end of the pool, mark the excess hose hanging over the deck, turn off your pool pump, and cut first 6 ft. section of hose, closest to the wall, the length of excess.
4. **IMPORTANT:** *Please double check the hose length* to insure you will be getting the maximum performance from your pool cleaner. The hose lengthens when under pressure (when your pump is on).

F. Hooking up the Legend® II

1. Remove the Pressure Tester from the free end of the Feed Hose by unscrewing the Mender Nut, left hand thread (reverse). (See illustration below.)

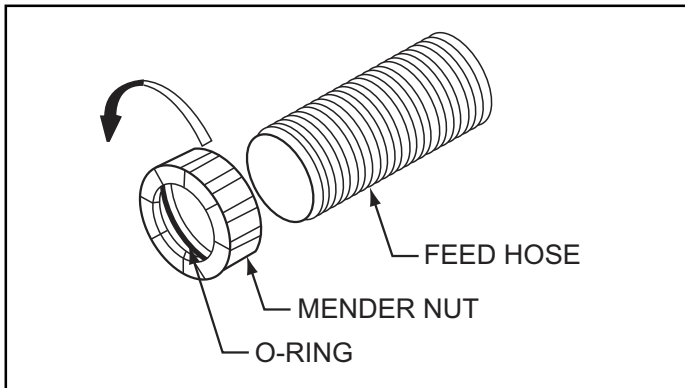

2. Place mender nut on Legend® II Swivel Mast. Connect the open end of the Feed Hose to the top of the Legend® II Swivel Mast and secure with the mender nut. The arch of the Feed Hose should align in the same direction as the Swivel Mast, there should be no twist in the Feed Hose after connection. (See illustration below.)

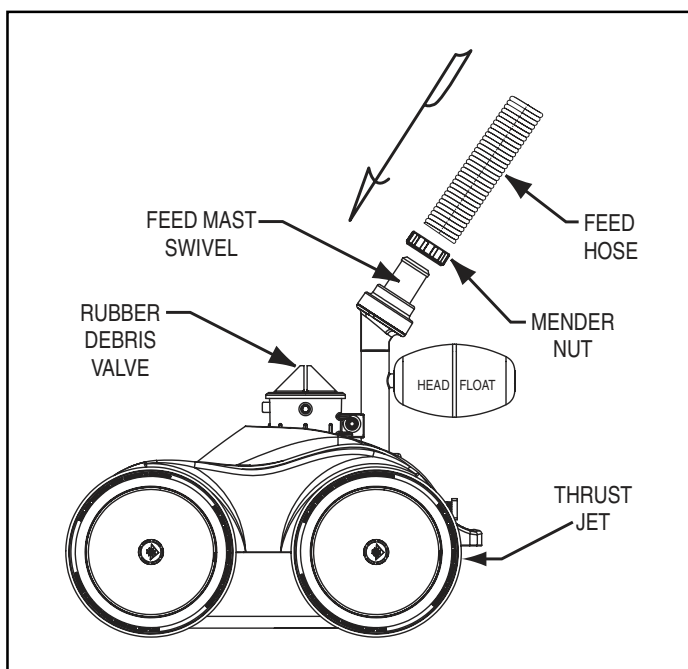

3. Carefully twist lock the Sand & Silt debris bag onto the top of the Legend® II Vacuum Tube. Make sure there is a Rubber Debris Valve attached to the top of the Vacuum Tube before locking on the Sand & Silt bag, (this valve is similar to a check valve to help keep debris inside the bag when the water pressure is off).
4. Attach the Sand & Silt bag clip to the space between the Back-Up Valve and the 18" hose.
5. Gently place the Legend® II in the pool. Turn on the pool filtration pump.
6. Check to make sure the wheel RPM is between 25-32. See [page 5](#) for instructions on wheel RPM.

G. Checking Operation

When operating correctly, the Legend® II will travel in a random pattern throughout the pool, vacuuming and sweeping the bottom. The climbing ability of the Legend® II is dependent on the pools structure and water flow coming into the pool. It will perform more efficiently in pools without sharp angles or curves in the transition from the floor of the pool to the wall.

The Legend® II comes with a Twist Lock Pressure Relief Valve (Wall Fitting). If the Legend® II is receiving too much water pressure, the Pressure Relief Valve in the Wall Fitting will release the excess water pressure.

Approximately every three minutes and 30 seconds the Legend® II will go into a back-up mode. The Back-Up Valve cycle time, while in the back-up mode, is approximately 30 seconds, pulling the Legend® II from it's current location increasing it's random pattern.

The Sweep Hose operates in a gentle sweeping motion to prevent debris from becoming trapped in hard to reach corners of the pools.

If the Legend® II does not travel to all areas of the pool, turn off the pool filtration pump and make the necessary adjustments from the instructions on the next page.

H. Fine Tuning the Legend® II

1. Thrust Jet Adjustment

There are two Thrust Jets located in the back of the Legend® II. These Thrust Jets alter the direction of the cleaner. The factory standard position for the jets is set slightly to the right. (See illustration below.)

In certain pools, altering the thrust jets can increase performance of the Legend® II. Moving the thrust jets up can increase climbing, and moving them down can decrease climbing. Moving the thrust jets to the left pushes the unit left and moving them to the right pushes the unit right.

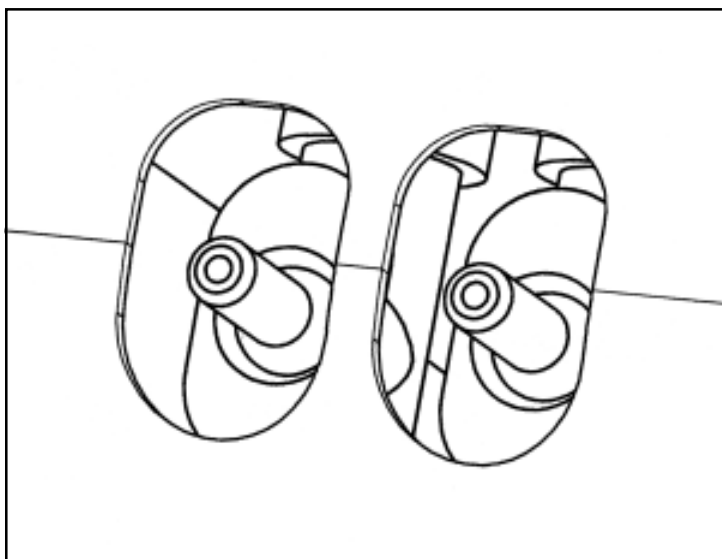

2. Sweep Hose Adjustment

The Sweep Hose operates in a gentle sweeping motion. To increase or decrease the motion of the Sweep Hose, adjust the screw located on the Swivel Mast Barb below the Ballast Float. Turning the screw clockwise will decrease the motion and counter clockwise to increase the motion of the Sweep Hose.

3. Checking Wheel RPM

To determine whether the Legend® II is receiving the proper water pressure, turn off the pool pump, and carefully remove the Legend® II from the pool.

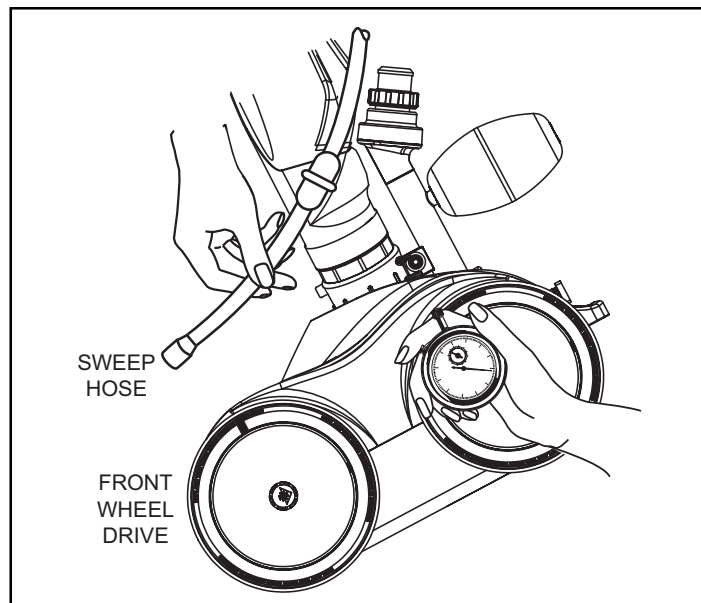

Mark the front drive Tire/Wheel with a marker, or use the Logo located on the side of tire as a marker to count the rotations of the wheel per minute.

Have someone turn on pool pump while you place the Legend® II in the pool just beneath the water surface. (Be sure to hold onto the Sweep Hose to avoid getting wet.)

Count the rotations of the marked wheel for exactly one minute. (Be sure the Back-Up Valve isn't cycling at this time.) The rotations will give you the Revolutions Per Minute, (RPM).

For proper performance, the Legend® II operates between 25-32 RPM. If the RPM is below 25 then closely follow the instructions on the next page.

3. Checking RPM - (cont.)

1. Clean the Screen located inside the Wall Fitting. A small amount of debris will significantly affect the performance of the cleaner.
2. Clean the skimmer basket, pump basket and pool filter.
3. If an adjustable Gate (3-way) Valve has been installed, adjust the valve to increase water flow to the Legend® II.
4. If the RPM is more than 32, at the Wall Fitting, unscrew the Pressure Relief Valve slowly until the RPM falls between 25-32. Again, if an adjustable gate (3-way) valve has been installed, adjust the gate valve to decrease water flow to the Legend® II.
5. If you continue to have problems with either the water flow or obtaining the specified water pressure to operate the Legend® II, call your Professional Pool Dealer.



If you have any additional questions, please contact Pentair Water Pool and Spa, Inc., Technical Support Department at: 1-800-831-7133, Monday through Friday.

III. Operation/Periodic Maintenance

A. Connecting/Disconnecting the Legend® II

Turn off pool pump. Then take the Wall Fitting and twist lock the Wall Fitting clockwise into the Wall Adapter. To disconnect the Legend® II, unlock and twist counter clockwise. The Wall Adapter should remain in the pool wall.

B. Turning On/Off the Legend® II

The Legend® II operates off a filtration pump coming from the equipment pad, and can be turned on or off by merely turning on/off your pump time clock.

C. Cleaning the Sand & Silt Bag

Carefully unlock the debris bag from the vacuum tube. Use your thumb to push the "U" shaped snap lock closure upward until it snaps open. Make sure to swing it away from the opening. Open the bag and remove debris.

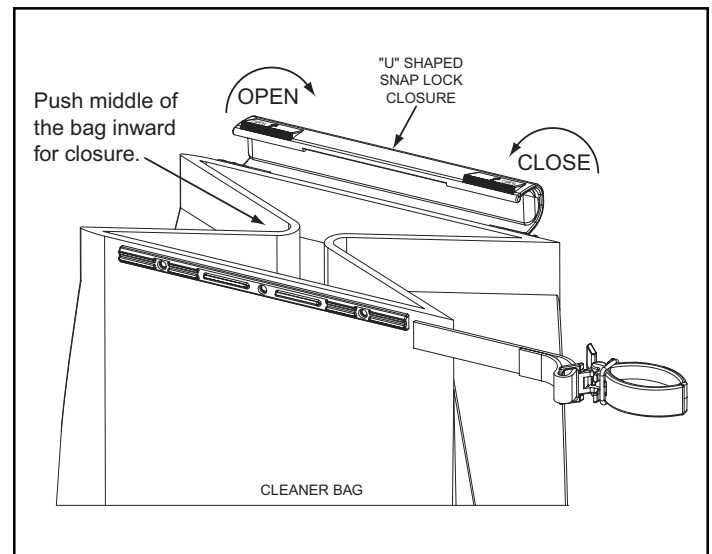

To close, push the middle of bag inward, as shown, and bring the edges together to make them stack like an accordion. Swing the "U" shaped snap lock closure back to the closing position.

C. Cleaning the Sand & Silt Bag - (cont.)

Gently push on top of the "U" shaped snap lock closure to make sure it snaps into place.

Your debris bag is ready to be reinstalled onto your cleaner.

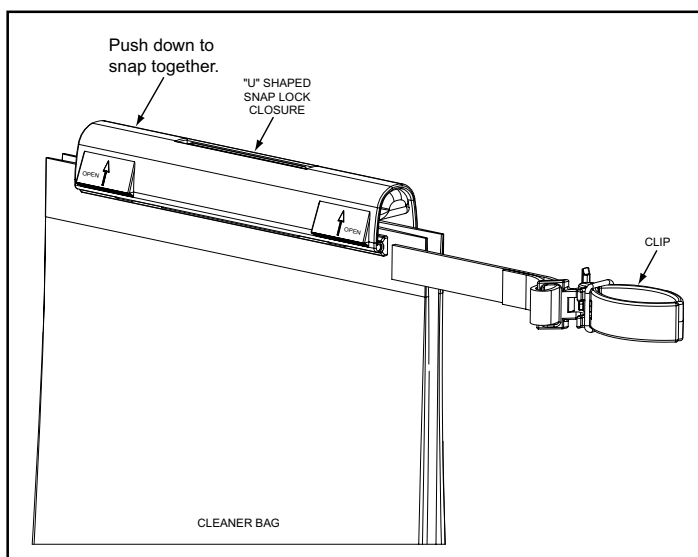

If you have a lot of debris in your pool, especially after a storm, you can run your Legend® II in two shorter cycles per day and empty the debris bag between cycles.

Reconnect the debris bag to the vacuum tube. Do NOT over turn.

A Helpful Hint: It is easier to empty the debris bag when it is dry. A second bag may be used while the full debris bag is drying.

It's best to empty the debris bag when it becomes half full. The Legend® II will have better performance if the bag is not overloaded.

D. Periodic Maintenance

The following parts are wear items that should be checked, maintained or replaced as needed. Wear items are considered any working or moving part(s) being worn due to the use of the cleaner. **Wear items are not covered under warranty.**

1. Wall Fitting Screen

Inside the wall fitting is a filter screen that acts as a secondary filter. This screen is to keep debris that is passed by the pool filter out of the Legend® II. *Running the Cleaner without the filter screen can damage the Legend® II and will void the warranty.*

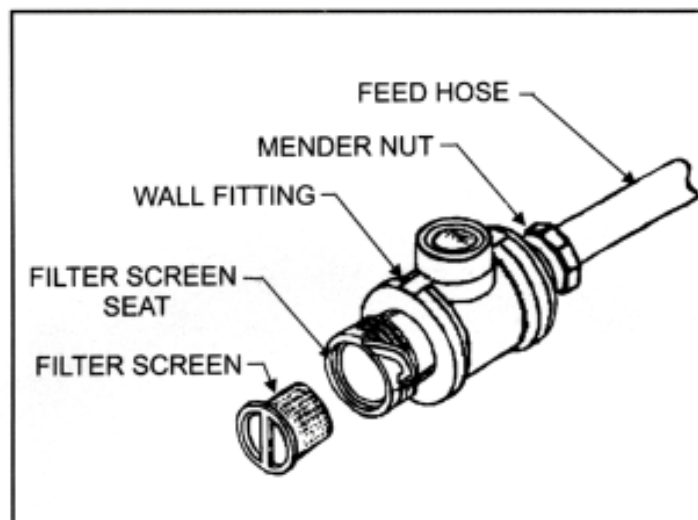

A continuous plugged or dirty screen is a sign of problems in your pool filtration system and you need to contact your local pool professional.

To clean the filter screen, pull the screen out from inside the Wall Fitting and rinse thoroughly and push back inside the wall fitting.

Whenever cleaning, back washing or repairing filter, remove the wall fitting and flush out the dedicated line before using the Legend® II.

III. Operation/Periodic Maintenance - (cont.)

2. Tires & Bearings

The tires are designed to protect the bottom of your pool and provide better traction. You need to rotate or replace the tires when the tire is worn up to the wear groove.

The Wheel Bearings are warranted free of defects when shipped from Pentair Water Pool and Spa, Inc., and are considered a wear item. A good bearing will spin freely.

3. Roller Rings

Your Sweep Hose has a series of Roller Rings to protect the Sweep Hose. Replace the rings as needed. You can rotate the Roller Rings to prevent flat spots.

4. Debris Bags

Fine Mesh Sand & Silt Bag

The Legend® II comes with a Sand & Silt bag for general use in all pools. We do not recommend using the fine mesh bag to pick up leaves and twigs or other large debris for they have sharp points and edges that can poke holes and eventually rip the bag.

Optional Leaf Bag

The leaf bag is a larger mesh bag made to pick up heavier debris such as leaves, twigs, acorns, etc. This bag can be helpful especially after a storm.

A Helpful Hint: To prolong the life of bags, remove cleaner from pool before adding chemicals.

5. Sweep Hose

The Sweep Hose is provided to help keep the bottom and sides of your pool clean. The Sweep Hose is warranted free of defects when shipped from the factory, and is considered a wear item.

6. Debris Valve

This valve is located under the Debris Bag, it is designed to keep the debris inside the bag. It functions like a check valve to allow the debris to only enter through the bag one way. Replacement is needed when valve begins to stiffen.

E. Back Washing the Pool Filter

Always disconnect the Legend® II from the pool wall before cleaning or back washing the pool filter. After cleaning or back washing, let the pool filtration system run for a minimum of five minutes to flush out the return lines before reconnecting the Legend® II.

III. Operation/Periodic Maintenance - (cont.)

F. Storage and Winterizing

Never leave or store the Legend® II in direct sunlight. When storing the Legend® II for the winter, be sure to drain all the water from it. This is important since freeze damage is not covered under the warranty. Also, remove the Wall Fitting.

G. Accessories

1. Leaf Bag

(See previous page)



IV. TROUBLESHOOTING AND PERFORMANCE TIPS

To insure the best performance from your cleaner, follow the troubleshooting guide listed below.

A. PROBLEMS & SOLUTIONS

Problem: Legend® II doesn't move or moves sluggishly or hangs up on steps.

- Solution:**
1. Be sure filter and filter pump are on and working properly. (You may need to clean your pool filter system.)
 2. Check to see if the skimmer and basket are clean.
 3. Check the Wall Fitting screen for debris and rinse clean.
 4. Check wheel RPM, (see [pages 5-6](#)).
 5. Determine if the Back-Up Valve is cycling. (Hold the valve out of the water and the jet should come on for approx. 30 seconds and shut off for approx. 3 minutes and 30 seconds.)
 6. Check all the Hose connections and Swivels for leaks that can cause loss of water pressure.
 7. Check debris that may be jammed in the gear teeth on one of the front drive wheels. Gently rotate the front wheels backward to dislodge debris.

Problem: Legend® II flies around pool.

- Solution:**
1. Check wheel RPM, and if more than 32 RPM make adjustment at Wall Fitting by turning the Pressure Relief Valve slowly until RPM falls between 25-32; or if an adjustable gate valve has been installed, adjust the valve to decrease water flow.
 2. Air in system, see a Pool Professional.

Problem: Legend® II will not back up.

- Solution:**
1. Determine if the Back-Up Valve is cycling. (Hold the valve out of the water and the jet should come on for approx. 30 seconds, and shut off for approx. 3 minutes and 30 seconds.)
 2. Check the wheel RPM, (see [pages 5-6](#)).
 3. Empty the debris bag if full or half full.

Problem: Legend® II will not climb.

- Solution:**
1. Even if your pool doesn't show algae you still need to brush the sides of the pool wall.
 2. Check the wheel RPM, (see [pages 5-6](#)).
 3. Reposition the Thrust Jet. Loosen the two screws to adjust the Thrust Jet.

A reminder: The climbing ability of the Legend® II is dependent on the pool's shape and available water pressure. It will climb better in pools without sharp angles or curves in the transition from the pool floor to the pool wall.

Problem: Hoses tangling.

- Solution:**
1. Check the length of the Feed Hose, they may be too long. (See [pages 3-4](#).)
 2. Check to see that the Feed Hose is floating on top of surface. Check hose floats for even spacing.
 3. Twist the Hose Swivels to see if they spin freely and replace any that will not.
 4. Lay out the Feed Hose straight in the full sun to remove any memory.

IV. TROUBLESHOOTING AND PERFORMANCE TIPS

A. PROBLEMS & SOLUTIONS - (cont.)

Problem: Sweep Hose is sucked into the cleaner.

Solution: 1. Adjust the Sweep Hose using the Adjustment Screw located on the bottom of the Swivel Mast. Turn Adjustment Screw clockwise until the Sweep Hose is in a gentle sweeping motion.

Problem: Sweep Hose breaks surface and sprays nearby windows, patio decks and bystanders.

Solution: 1. Adjust Sweep Hose to a gentle sweeping motion.

TIPS FOR CUTTING HOSE IN A SMALL POOL, AND FOR ADDING HOSES FOR LARGE POOLS

1. Tips on Hose Cutting for Larger Pools.

If the hose is short of the farthest end of the pool, add an additional section of hose (Part # LX17/360020), one Swivel (Part # LX19/360023), two Mender Nuts w/O-Rings (Part # LX20/360022), and one Hose Float (Part # LXD10/360019). See diagram below. Re-measure and follow guides on [pages 3-4](#).

1. Tips on Hose Cutting for Smaller Pools.

If the hose hangs over the deck more than 9 ft. or the pool is less than 6 ft. deep and narrow, cut 36 in. off the 5 ft. section hose at the end of the feed hose and remove one float. Then remove one 6 ft. hose (see diagram), 1 swivel and 2 mender nuts. Re-measure and cut hose according to the guides on [pages 3-4](#).

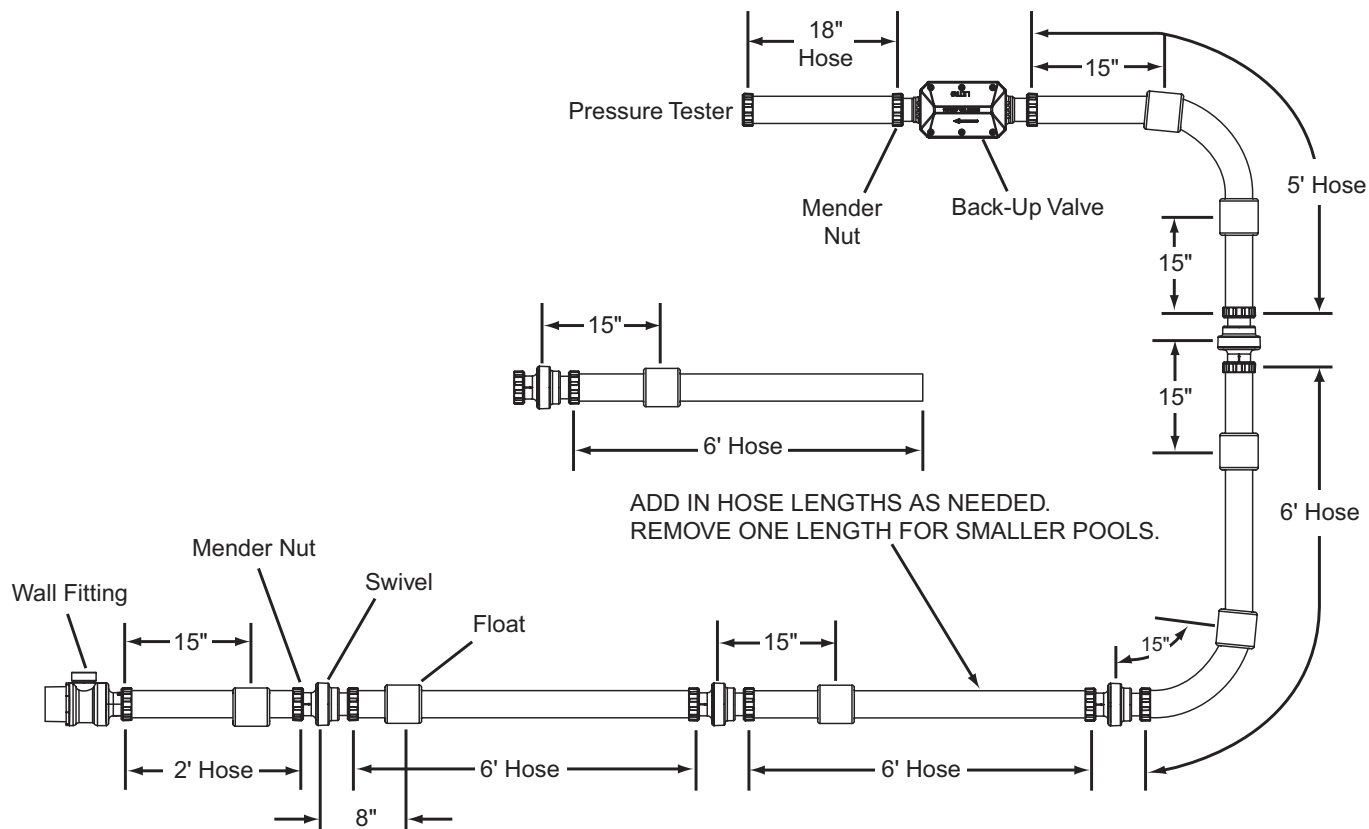

LEGEND® II PARTS LIST

Diagram#	Part #	Description	Qty.
1	360003	Top Cover	1
2	LXU145N	Main Frame	1
2	360016	Main Frame Grey	1
3	360004	Bottom Cover	1
3	360011	Bottom Cover Grey	1
4	LXU6	Feed Mast w/O-Ring & Swivel Grey	1
4	360017	Feed Mast w/O-Ring & Swivel	1
5	EC86	Turbine Drive Shaft - Complete	1
6	EC83	Turbine Spacers	2
7	EC80	Turbine Bearings	2
8	EA40	Turbine Shaft Shield	1
9	LXC110	Turbine Cover w/Elbows	1
10A & 10B	EC120	Turbine/Venturi Hose 7¾" length	2 & 1
10A & 10B	LLC120G	Turbine/Venturi Hose 7¾" length - Grey	2 & 1
11	EB5L	Sweep Hose - Complete	1
11	LLB5G	Sweep Hose - Complete - Grey	1
12	EB10	Sweep Hose - Wear Ring	9
13	EB25	Sweep Hose - Jet w/Collar	1
13	LLB25PM	Sweep Hose - Jet w/Collar - Grey	1
14	370198	Sweep Hose Adjustment Screw	1
15	EA20	Ballast Float	1
15	LLA20G	Ballast Float - Grey	1
16	EH07	Sweep Hose - Hose Sleeve	4
16	LLH07PM	Sweep Hose - Hose Sleeve - Grey	4
17	EU15	Coarse Mesh Bag (Optional - not shown)	1
17	EU15G	Coarse Mesh Bag- Grey Collar (Optional - not shown)	1
18	360002	Fine Mesh Bag - Mechanical Lock	1
18	360009	Fine Mesh Bag Grey - Mechanical Lock	1
18	EU16	Fine Mesh Bag- Velcro Brand Fastener	1
18	EU16G	Fine Mesh Bag- Velcro Brand Fastener - Grey	1
19	EU9	Debris Valve	1
20	EU7	O-ring for Feed Mast	1
21	E18	O-ring for Thrust Jet	1
22	EC130	Thrust Jet	1
23	EC135	Thrust Jet - Plate	1
23	LLC135G	Thrust Jet - Plate - Grey	1
24	EC65	Axle - Large Wheels	4
25	EC70	Axle Plate	4
26	370258Z	Axle Screw w/Lock Washer	8
27	360006	Wheel w/o Bearings	4
28	EC60	Wheel Bearings - Only	8
29	EC55	Wheel Screw - Plastic	4
29	LLC55PM	Wheel Screw - Plastic - Grey	4
30	360007	Wheel - Rubber Tire	4
30	360012	Wheel - Grey Tire	4
31	360005	Hub Cap	4
31	360013	Hub Cap - Grey	4
32	EB15	Hose Clamp	7
33	EC40	Screw	7
34	EC64	Wheel - Plastic Washer	4
35	EC131	Thrust Jet Repair Kit, includes: EC130, EC135 and E18	1
35	360014	Thrust Jet Repair Kit, includes: EC130, LLC135 and E19	1
36	EA30	Screw for EA40 and LXC110	5
37	EU147	Snap Fit Vac Tube Posts	2
37	LLU147G	Snap Fit Vac Tube Posts - Grey	2
38	EU79	Nut & Bolt - Feed Mast to Vac Tube	1
39	LXU8	Venturi Jets	2
40	EU80	Screw - Top and Bottom Cover	4
41	370017	Sweep Hose - Scrubber	1
-	EH09C	Sweep Hose Weight (Optional - not shown)	1
42	360008	Clip Hose for 360002	1
42	360015	Clip Hose - Grey - for 360009	1

LEGEND® II EXPLODED VIEW

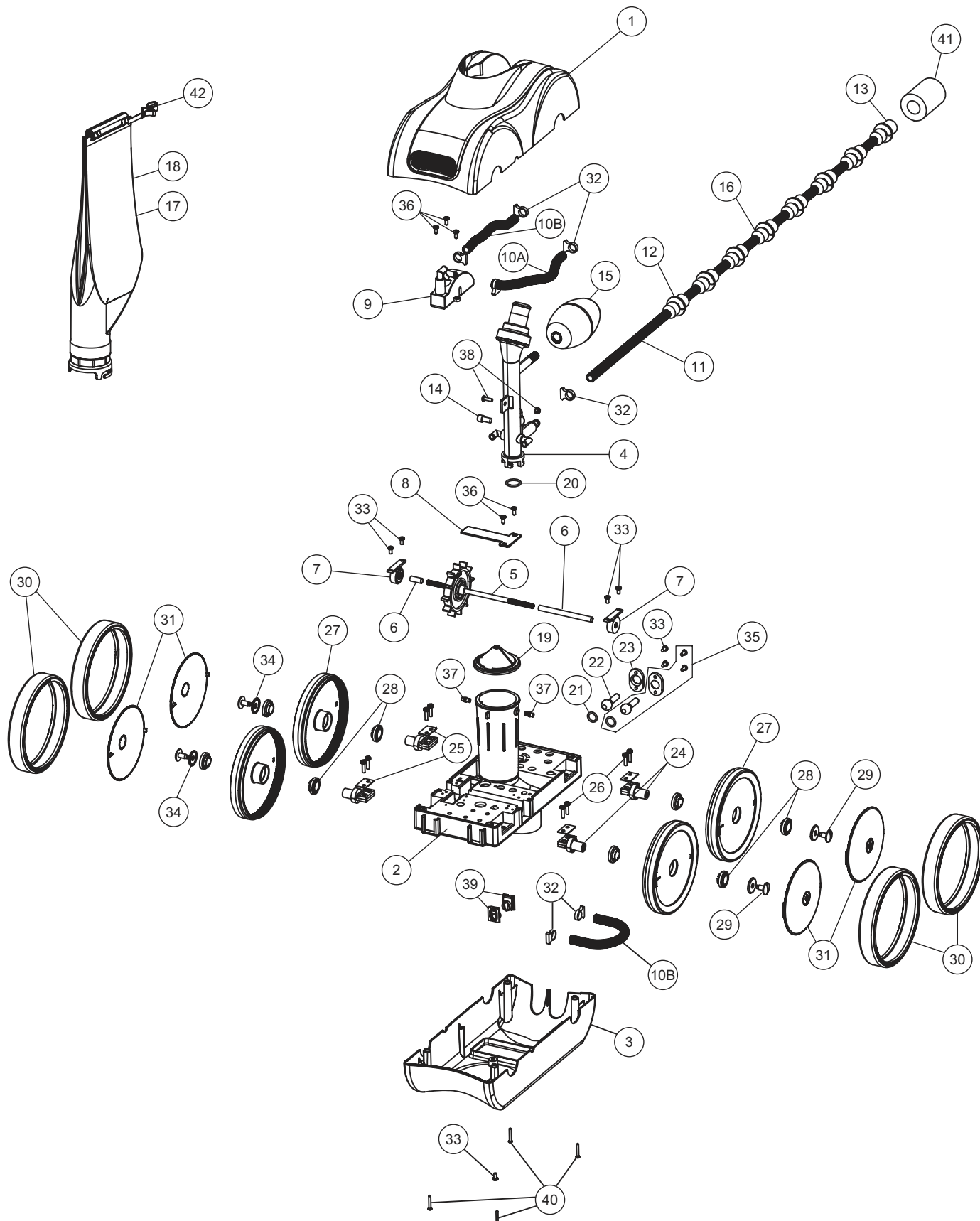

LEGEND® II PARTS LIST

SEE PAGE 15 FOR DIAGRAM (H2 - H9)

Diagram#	Part #	Description	Qty
H2	LX10	Back-Up Valve - Low Pressure	1
H2	360018	Back-Up Valve - Low Pressure	1
H2	E15	Back-Up Valve - Screw Housing Body	6
Inside H2	E13	Back-Up Valve - Housing O-Ring	1
Inside H2	E14	Back-Up Valve - O-Ring Gear Assembly	1
Inside H2	LX16	Back-Up Valve - Gear Assembly	1
H3	LXD10	Feed Hose Float - White	7
H3	360019	Feed Hose Float - Grey	7
H4	LX18	Feed Hose - White - 2 ft. Section	1
H4	360021	Feed Hose - Grey - 2 ft. Section	1
H5	LX17	Feed Hose - White - 6 ft. Section	4
H5	360020	Feed Hose - Grey - 6 ft. Section	4
H6	LX20	Feed Hose Mender - White w/O-ring #0252	12
H6	360022	Feed Hose Mender - Grey w/O-ring #0253	12
H7	LX19	Feed Hose Swivel - White	4
H7	360023	Feed Hose Swivel - Grey	4
H8	LXW22	Wall Fitting Complete - White	1
H8	360024	Wall Fitting Complete - Grey	1
Inside H8	E23	Wall Fitting Adapter - White	1
Inside H8	LL23PM	Wall Fitting Adapter - Grey	1
Inside H8	E21	Wall Fitting O-ring	2pk
Inside H8	E24	Wall Fitting Screen	1
Inside H8	LX25	Wall Fitting - Valve Assembly - White	1
Inside H8	360025	Wall Fitting - Valve Assembly - Grey	1
H9	LX26	Pressure Tester	1

LEGEND® II PARTS LIST

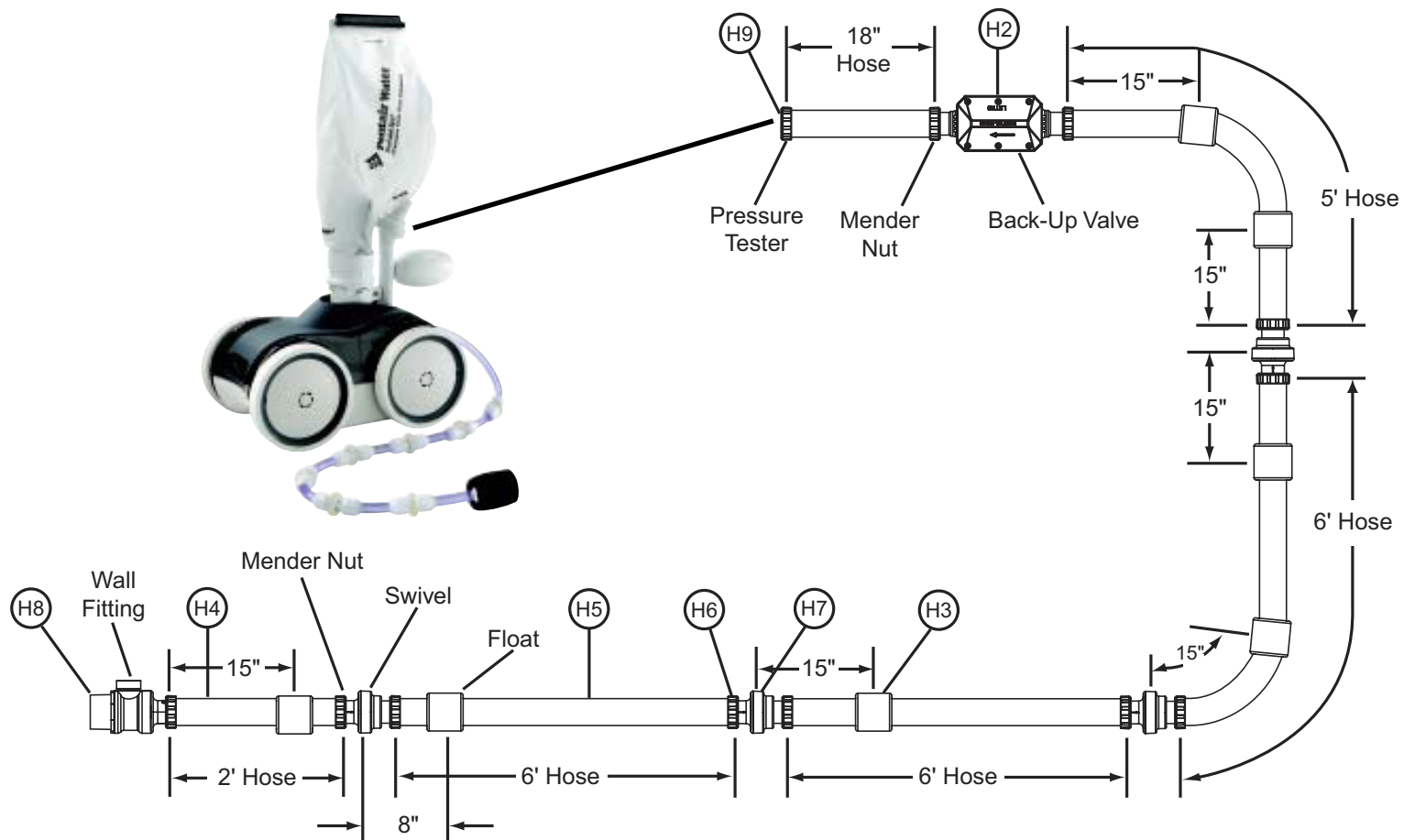

SAVE THESE INSTRUCTIONS.

Notes

