

# 20" HOT WATER POST-FILTER SYSTEM INSTALLATION MANUAL

PHT20-P

## Installation Instructions

### PARTS OF THE SYSTEM

- A) One (1) Filter Housing
- B) One (1) Spanner Wrench
- C) One (1) Mounting Bracket
- D) Four (4) Phillip Screws
- E) One (1) 5-Micron Filter
- F) One (1) Brass Shut Off Valve

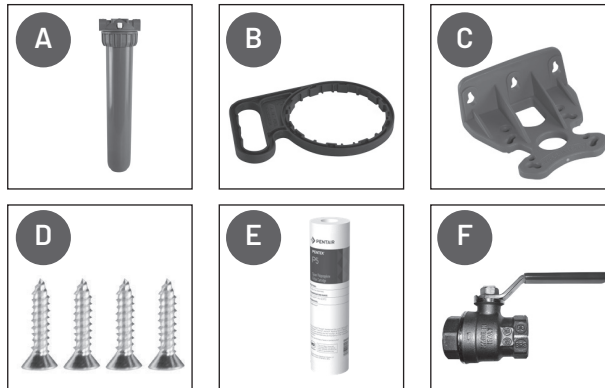

### PRODUCT OPERATION AND SPECIFICATIONS

Specification Description	PHT20-P
Rated Service Flow	20 gpm
Minimum Working Pressure	25 psi
Maximum Working Pressure	116 psi
Operating Temperature	36°F - 176°F
pH Range	6.5 - 9.5

### INSTALLATION

1. Unpackage and account for all items before starting installation.
2. Unscrew the cover from the housing by rotating the housing collar clockwise.
3. Attach the cover to the bracket using the four (4) Phillips head screws through the elongated holes in the bracket. Make sure to orientate the IN and OUT correctly for your install.
4. Turn off the main water supply.
5. Determine the location on the hot water line after the water heater for install.
6. Install the 3/4" brass shut off valve prior to the filter system.
7. Attach the cover and bracket to the wall using the proper fasteners (not included).
8. Make final plumbing connections using four (4) male 3/4" fittings (not included).
9. Unwrap and install the 5-micron filter into the housing, centering on the stand pipe in the bottom of the housing.
10. Lubricate the preinstalled o-ring with food grade silicone grease and reinstall.
11. Attach the housing to the cover by rotating the housing collar counter clockwise.

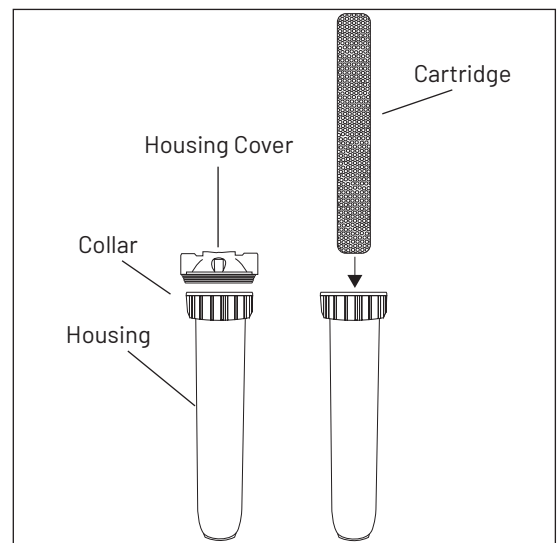

## INSTALLATION (CONT.)

---

12. Slowly turn on the main water supply.
13. Unscrew the white bleeder valve to release the trapped air and re-tighten.
14. Check for leaks.

Top of Pentair Hot Water Post-Filter

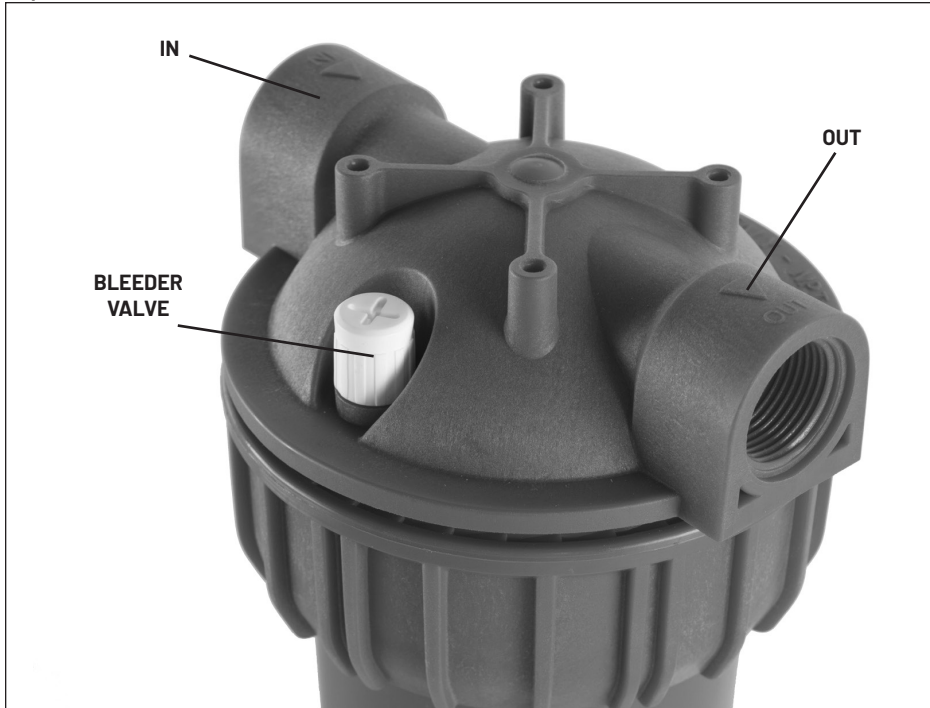

Front of Pentair Hot Water Post-Filter



## MAINTENANCE:

---

- The 5-micron filter needs to be replaced every twelve (12) months.

## CARTRIDGE REPLACEMENT

---

1. Turn off the shut off valve to the system.
2. Rotate the bleeder valve to relieve the pressure.
3. Apply wrench to the housing collar and turn clockwise to loosen (to the left).
4. Remove the old o-ring and filter.
5. Unwrap and install a new filter, centering on the stand pipe.
6. Install a new o-ring lubricated with food grade silicone grease.
7. Re-install housing and tighten collar (do not over tighten).
8. Turn main water supply on slowly.
9. Rotate the bleeder valve to release trapped air and re-tighten.
10. Check for leaks.

For details on your Pentair product warranty, please visit [pentair.com/assets/residential-filtration-warranty](https://pentair.com/assets/residential-filtration-warranty)



13845 Bishops Dr. | Suite 200 | Brookfield, WI 53005 | United States  
[waterpurification@pentair.com](mailto:waterpurification@pentair.com) | Customer Care: 800.279.9404 | [tech-support@pentair.com](mailto:tech-support@pentair.com)

© 2022 Pentair. All indicated Pentair trademarks and logos are property of Pentair. Third party registered and unregistered trademarks and logos are the property of their respective owners.

4006094 Rev D OC22